

**DIN 3015 - Part 2
Heavy Series Clamps**

Product Code
Jaws Material
Metal Assemblies

PCH
PP, PA, AL, SS
CS, SS

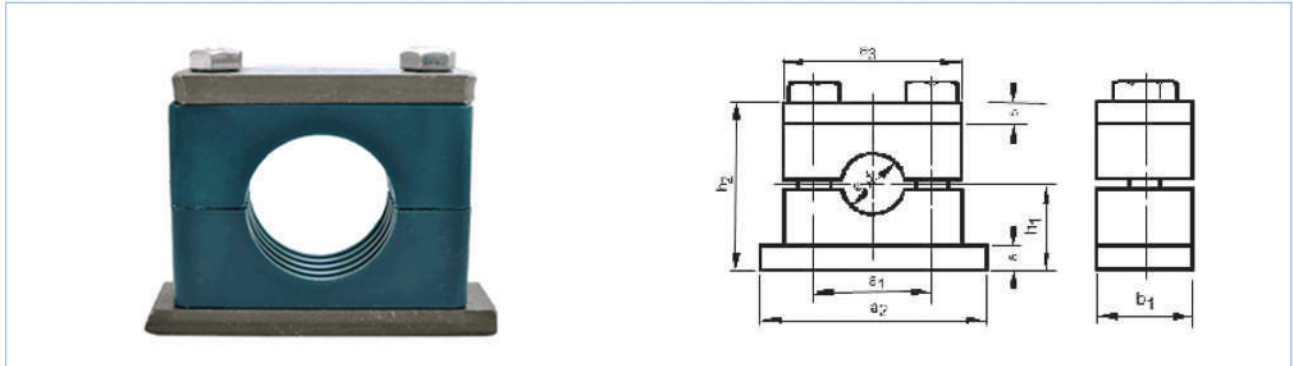

DIN / JE GROUP	PIPE OD Dia	a ₃	a ₁	h ₂	g	b ₁	a ₂	s	BOLT SIZE									
1	6	55	33	48	0.6 MIN	30	70	8	M10x45									
	6.4																	
	8																	
	9.5																	
	10																	
	12																	
	12.7																	
	13.5																	
	14																	
	15																	
2	16	70	45	64	0.6 MIN	30	85	8	M10x60									
	17.2																	
	18																	
	19																	
	20																	
	21.3																	
	22																	
	25																	
	26.9																	
	28																	
3	30	85	60	76	0.6 MIN	30	100	8	M10x70									
	33.7																	
	35																	
	38																	
	42																	
	4									48.3	115	90	117	2 MIN	45	140	10	M12x100
										50.8								
										60.3								
										63.5								
										65								
5		70	152	122	140	2 MIN	60	180	10	M16x130								
		73																
		76.1																
		88.9																
		102																
	6	114									206	168	197	2 MIN	80	226	15	M20x190
		127																
		133																
		141																
		7																
168																		

**DIN 3015 - Part 2
Heavy Series Clamps**

Product Code **PCH**

Jaws Material Code
Polypropylene - PP
Poly Amide - PA
Aluminium - AL

Jaws Order Code
Group-Material Code-
Pipe OD-Part Code

Eg: For Jaws

1-PP-06-JPCH indicates
6mm OD PP Clamp Halves
Heavy Series



DIN / JE GROUP	PIPE OD - Dia D1			JAWS - JPCH												
	MM	INCH OD	INCH NB	L1	L2	H	S	WIDTH								
1	6	1/4"	G1/8	55	33	32	0.6 MIN	30								
	6.4															
	8															
	9.5															
	10															
	12															
	12.7															
	13.5															
	14															
	15															
2	16	3/4"	G1/2	70	45	48	0.6 MIN	30								
	17.2															
	18															
	19															
	20															
	21.3															
	22															
	25															
	26.9															
	28															
3	30	1 1/4"	G1	85	60	60	0.6 MIN	30								
	32															
	33.7															
	35															
	38															
	42															
	4								48.3	2"	G1 1/2	115	90	89	2 MIN	45
									50.8							
									55							
									57							
60.3																
63.5																
65																
70																
73																
75																
5	76.1	3"	G2 1/2	152	122	120	2 MIN	60								
	80															
	88.9															
	102															
	108															
	6								114.3	4 1/4"	G4	206	168	167	2 MIN	80
									127							
									133							
									141							
									7							
168																

**DIN 3015 - Part 2
Heavy Series Clamps**

Product Code **PCH**



DIN / JE GROUP	BOTTOM PLATE [BPH]					JE PART NO.	DOUBLE BOTTOM PLATE [DBPH]					JE PART NO.
	L1	L2	G	S	B		L1	L2	B2	S	B	
1	70	33	M10	8	30	BPH1	70	33	30.5	8	60	DBPH1
2	85	45	M10	8	30	BPH2	85	45	30.5	8	60	DBPH2
3	100	60	M10	8	30	BPH3	100	60	30.5	8	60	DBPH3
4	140	90	M12	10	45	BPH4	140	90	46	10	90	DBPH4
5	180	122	M16	10	60	BPH5	180	122	61	10	120	DBPH5
6	226	168	M20	15	80	BPH6	226	168	81	15	160	DBPH6
7	270	205	M24	15	91	BPH7	270	205	91	15	180	DBPH7

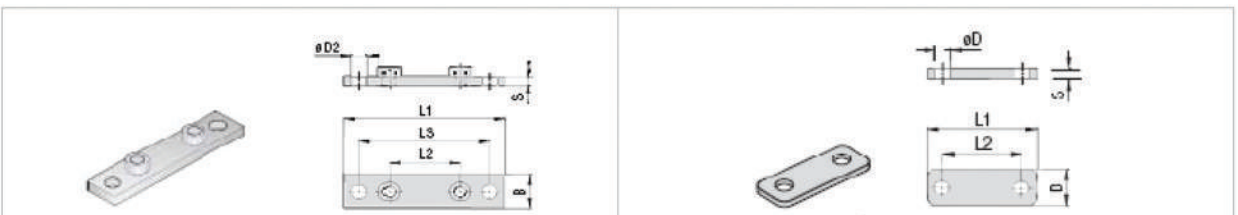

DIN / JE GROUP	ELONGATED BOTTOM PLATE [EBPH]					JE PART NO.	TOP PLATE [TPH]					JE PART NO.
	L1	L2	L3	S	D2		L1	L2	D Dia	S	B	
1	113	33	30.5	8	13	EBPH1	55	33	11	8	30	TPH1
2	125	45	30.5	8	13	EBPH2	70	45	11	8	30	TPH2
3	140	60	30.5	8	16	EBPH3	85	60	11	8	30	TPH3
4	187	90	46	10	21	EBPH4	115	90	14	10	45	TPH4
5	238	122	61	10	26	EBPH5	152	122	18	10	60	TPH5
6	309	168	81	15	31	EBPH6	206	168	22	15	80	TPH6
7	370	205	91	15	31	EBPH7	251	205	26	15	91	TPH7



DIN / JE GROUP	STACKING PLATE					JE PART NO.	STACKING BOLT					JE PART NO.	HEX BOLT G x L	SOCKET HEAD BOLT G x L
	L1	L2	B1	B2	S		G	L1	L2	L3	SW			
1	56	13	30	15.2	8	SPH1	M10	49	25	15	15	SBH1	M10x45	M10x30
2	70	32	30	15.2	8	SPH2	M10	65	40	15	15	SBH2	M10x60	M10x40
3	85	40	30	15.2	8	SPH3	M10	77	51	15	15	SBH3	M10x70	M10x50
4	116	68	45	17.2	10	SPH4	M12	110	82	18	17	SBH4	M12x100	M12x80
5	153	96	60	22	10	SPH5	M16	144	110	24	21	SBH5	M16x130	
6	206	130	80	28	15	SPH6	M12	200	150	30	27	SBH6	M20x190	
7	251	166	90	31	15	SPH7	M24	240	180	50	30	SBH7	M24x220	